



APPROVED



ROTAX MOJO MAX Challenge
Technical Regulations 2010
(The Technical Regulations 2010 replace the Technical Regulations 2009)
Version 2010.02.04

1. Categories:

Categories racing in the ROTAX MOJO MAX Challenge GRAND FINALS (RMCGF) and International ROTAX MOJO MAX Challenge Events (IRMCE) like the ROTAX MOJO MAX EURO Challenge are divided into the following groups:

- ROTAX 125 Junior MAX (cylinder capacity 125 cc)
- ROTAX 125 MAX/MASTERS (cylinder capacity 125 cc)
- ROTAX 125 MAX DD2/MASTERS (cylinder capacity 125 cc, 2-speed)

Categories racing in the ROTAX MOJO MAX Challenge (RMC),

- ROTAX 125 Micro MAX (cylinder capacity 125 cc)
- ROTAX 125 MINI-MAX (cylinder capacity 125 cc)
- ROTAX 125 Junior MAX (cylinder capacity 125 cc)
- ROTAX 125 MAX/MASTERS (cylinder capacity 125 cc)
- ROTAX 125 MAX DD2/MASTERS (cylinder capacity 125 cc, 2-speed)

2. Amount of equipment:

For each race event, from non-qualifying practice to the final, maximum following amount of equipment is allowed:

- 1 chassis
- 2 sets of dry tires + 1 front + 1 rear spare tires
- 2 sets of wet tires + 1 front + 1 rear spare tires
- 2 engines

For Canada, the equipment allowed is from qualifying session to the final race. The event organizer may specify the number of tires allowed for the event in the supplemental regulation of the event.

3. Kart:

3.1 Chassis:

For national RMC's any chassis sanctioned by an authorised ROTAX distributor is allowed.

For 125 Micro-Max and 125 Mini-Max, see the specific technical regulation for these classes.

Junior MAX and 125 MAX classes

Chassis tubing: round tubing only.

Maximum diameter of rear axle = 50 mm, minimum wall thickness according to CIK-FIA rules.

At IRMCE and RMCGF chassis with a valid CIK-FIA homologation only are allowed.

Any brake system must have a valid CIK-FIA homologation.
Front brakes are not allowed in the 125 Mini-Max and 125 Junior MAX classes.
Front brakes are allowed in 125 MAX class only.

For Canada, all braking systems must be operated simultaneously by a single foot pedal unless necessitated by physical handicap and approved by the event scrutineer.

125 MAX DD2 class

For all national RMC, IRMCE and the RMCGF 125 MAX DD2 classes, chassis approved by BRP-POWERTRAIN only are allowed to be used (approved chassis will be listed at the web page: www.maxchallenge-rotax.com).

Chassis must be designed according to CIK-FIA rules for shifter classes (front- and rear brakes mandatory).

Any brake system must have a valid CIK-FIA homologation.

ROTAX Rear Tire Protection System is mandatory to be used. Either old 2 tube version or latest 3 tube version, third tube might be mounted above or below the 2 main tubes, can be used. No part shall be added or removed from original content.

3.2 Bodywork

125 Junior MAX- and 125 MAX classes

For RMC, in accordance with regulations of national Federations or CIK-FIA.

At RMCGF and IRMCE, only bodywork with current CIK-FIA homologation validity is allowed, including the rear wheel protection system.

125 MAX DD2 class

In accordance with regulations of national Federations or CIK-FIA.

At RMCGF and IRMCE bodywork with current CIK-FIA homologation validity only is allowed. Only the current ROTAX rear wheel protection system is allowed.

4. Tires

125 Micro-Max and 125 Mini-Max

See the specific technical regulation for these classes.

125 Junior Max, 125 Max and Max DD2

At all RMC, IRMCE following only tires are allowed:

Dry (slick) tires:	MOJO Type: D1, D2 or D3
	Front: 4.5 x 10.0 - 5 Rear: 7.1 x 11.0 - 5
Wet tires:	MOJO Type: W2
	Front: 4.0 x 10.0 - 5 Rear: 6.0 x 11.0 - 5

For Canada: 125 Junior Max and 125 Max: D2 Wet: W2
Max DD2: D3 Wet: W2

Strictly no modifications or tire treatment allowed.

Note: with W2 tires, marked direction of rotation must be adhered to arrow on the sidewall.

5. Data acquisition:

The system, with or without a memory, may permit only the reading of: the engine revolutions (by induction on the spark plug HT cable), two indications of temperature, the speed of one wheel, an X/Y accelerometer and lap times.

6. Composite materials:

Composite materials (carbon fibre etc.) are banned except for the seat and the floor tray.

7. Safety of equipment

For RMCGF and IRMCE article 3 of CIK-FIA technical regulations apply.

For RMC overalls, helmets, kart shoes, gloves and other kind of driver protection must comply with the regulations of the national Federation or CIK-FIA.

8. Petrol:
Unleaded commercial quality from petrol station, maximum 98 octane.

9. Engines:
At RMC, RMCGF and IRMCE races, only engines which are in conformity with the following technical specification, are legal to be used.

For national RMC's, the only engines allowed to be used are engines which have been checked and sealed by the ROTAX Authorised Distributor of this territory or one of the Service Centres appointed by the Authorised Distributor.

For national RMC's, the ROTAX Authorised Distributor of this territory has to publish the lists of Service Centres which are legal to check and seal engines. For Canada, it will be posted on www.maxchallenge.ca.

For IRMCE, all ROTAX Authorised Distributors and their Service Centres only are allowed to check and seal engines. ROTAX will publish a list of Authorized Distributors and their Service Centres which are legal to check and seal engines.

For RMCGF only ROTAX employees are allowed to check and seal engines.

By sealing an engine, the ROTAX Authorised Distributors and their Service Centres take over the responsibility for the conformity of the engine according to the valid Technical Specification. Also a brand new engine must be checked according to the Technical Specification before sealing.

The engines have to be sealed with specific ROTAX engine seals (black anodised aluminium seal with "ROTAX"-logo and a 6 digit serial number see attached picture).

Further legal seals are, for 125 MAX class, black anodised aluminium seals with "JAG"-logo and 6 digit serial number and for 125 Junior MAX class, red anodised aluminium seals with "JAG"-logo and 6 digit serial number, red anodised seals with "KORRIDAS" AND 6 digit serial number for 125 Junior MAX and 125 MAX class.

By means of the steel cable, the engine must be sealed on one Allen screw (1) of the intake flange, on one stud screw (2) of cylinder and one Allen screw (3) of the cylinder head cover (see following pictures).

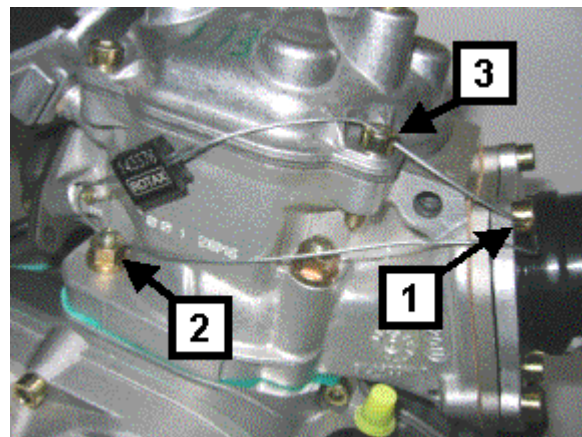

It is not allowed to pass the end of the sealing wire through the seal a second time (only as in above picture)

At every new sealing of an engine, the authority (ROTAX Authorised Distributor or their Service Centres) that checks and seals an engine is responsible for following indications at the Engine Identity Card which belongs to the owner of the engine:

- Serial number of the engine
- Serial number of the engine seal

- Stamp and signature of the company to be able to detect at scrutineering which authority has checked and sealed the engine.



At scrutineering the driver has to present:

- the engine(s) with the undamaged engine seal(s)
- the Engine Identity Card(s), showing the matching engine serial no.(s), the matching engine seal no.(s) and the stamp(s) and signature(s) of the authority(ies) that has (have) checked and sealed the engine(s).

The ROTAX Authorised Distributor organizing a national RMC may appoint before every RMC race a neutral Service Centre which will be the only one allowed to re-seal an engine between scrutineering and the final in the case of an engine failure. **For Canada**, if no Service Centre has been appointed, an engine can be opened between the scrutineering and the final race with the approval of the technical inspector. The check and repair, if needed, and re-sealing of the engine must be done under the technical inspector supervision.

During an IRMCE ROTAX Authorised Distributors and their Service Centres are not allowed to re-seal an engine between scrutineering and the final race.

The sealing of engines helps to reduce the times for scrutineering at races as during the race event just the accessories (carburettor, exhaust, radiator, etc) must be checked. Of course scrutineers can request to open and re-check an engine according to the Technical Specification, before or after a race or in case of a protest. If an engine seal has been broken (for which reason ever), the engine has to be checked completely according to the Technical Specification and must then be re-sealed by an ROTAX Authorised Distributor or one of its Service Centres.

Genuine ROTAX components only that are specifically designed and supplied for the 125 Junior MAX-, the 125 MAX- and the 125 MAX DD2 engines and for 125 Micro Max and 125 Mini-Max are legal, unless otherwise specified.

Neither the engine nor any of its ancillaries may be modified in any way. "Modified" is defined as any change in form, content or function that represents a condition or difference from that originally designed. This includes the addition and/or omission of parts and/or material from the engine package assembly unless specifically allowed within these rules. The adjustment of elements specifically designed for that purpose shall not be classified as modifications, i.e. carburettor and exhaust valve adjustment screws. **ANYTHING WHICH IS NOT EXPRESSILY ALLOWED IN THE TECHNICAL REGULATIONS IS FORBIDDEN.**

Internal additions:

No additional material may be added except in the case of engine repairs and shall only restore the engine or components to original specifications.

The use of thermal barrier coatings/ceramic coatings on or in the engine and on or in the exhaust system is prohibited.

The use of anti-friction coatings in or on the engine/engine components is prohibited. Customizing the cylinder head cover by painting is legal.

Legal additions:

Chain guard, engine mount, temperature gauge and tachometer/hour meter, inline fuel filter, catch can mounting brackets and supplemental ignition coil mounting brackets, within the limits specified in this document.

Non-tech items:





Non-original fasteners, circlips, washers, electrical mass cable, throttle cable housing, fuel and pulse line (type and size) are allowed unless otherwise specified.

Note: When taking any dimensional reading, of the following technical regulation, in the order of accuracy of 0,1 mm or even more precise, the temperature of the part must be between +10°C and +30°C.

Note: Before taking any decision based on this regulation a check for available bulletins is mandatory. They can be found under www.maxchallenge-rotax.com and, **for Canada**, under www.maxchallenge.ca.

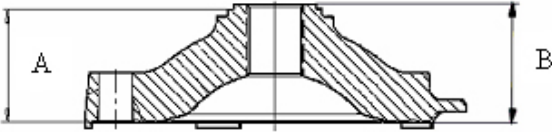
**9.1 Technical Specification (within the engine seal) for ROTAX kart engines
125 Junior MAX (15 kW)
125 MAX (21 kW).**

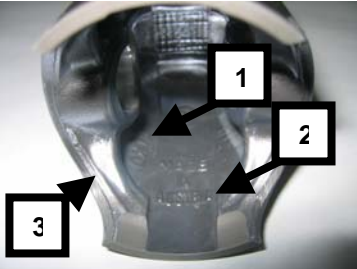
Squish gap	1.1 1.2	<p>125 Junior MAX 1,20 mm – 1,80 mm</p> <p>125 MAX 1,00 mm – 1,50 mm</p> <p>The squish gap must be measured with a certified slide gauge and by using a 2 mm tin wire. The crankshaft must be turned by hand slowly over TDC (top dead centre) to squeeze the tin wire. Recommended 2 mm tin wire: BRP-POWERTRAIN part no. 580 130</p> <p>The squish gap must be measured on the left and right side in the direction of the piston pin.</p> <p>The average value of the two measurements counts.</p>
Combustion Chamber insert	2.1 2.2 2.3 2.4	<p>Cast identification code has to be "223 389" or "223 389 1" or "223 389 2"</p> <p>Cast wording "ROTAX" and/or "MADE IN AUSTRIA" must be shown.</p> <div style="display: flex; justify-content: space-around;">  </div> <p>Heights of combustion chamber insert have to be 27,55 mm with a tolerance of +0,0/-0,1 mm (A) and 28,80 mm with a tolerance of +/- 0,2 mm (B).</p> <p>The profile of the combustion chamber insert has to be checked with a template (ROTAX part no. 277 390). The crack of light between the template and the profile of the combustion chamber insert has to be the same over the whole profile.</p>

		 <p>NOTE: This check is just for reference, in case of doubt, detailed measurements have to be performed to define conformity or non conformity.</p> 
Piston with ring assembly	<p>3.1</p> <p>3.2</p> <p>3.3</p>	<p>Original, coated or uncoated, aluminium, cast piston with one piston ring. The piston has to show on the inside the cast wording "ELKO" (1) and "MADE IN AUSTRIA" (2).</p> <p>Machined areas are: Top end of piston, outside diameter, groove for the piston ring, bore for the piston pin, inside diameter at bottom end of piston and some pre-existing factory removal (3) of flashing at the cut out of the piston skirt. All other surfaces are not machined and have cast surface.</p>  <p>Original, 1 mm, magnetic, rectangular piston ring. Piston ring is marked either with "E CRY K" or "ROTAX 215 547".</p> 
Gudgeon pin	<p>4.1</p> <p>4.2</p> <p>4.3</p>	<p>Gudgeon pin is made out of magnetic steel.</p> <p>Dimensions must be according to the drawing.</p> <p>The minimum weigh of the gudgeon pin must not be lower than 32,10 grams.</p>

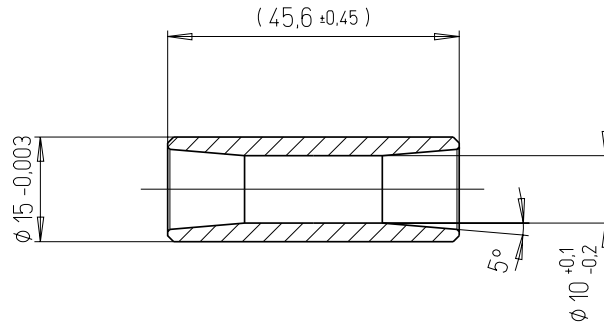

Cylinder

- 5.1 Light-alloy-cylinder with GILNISIL-plating. Any re-plating of cylinder is not allowed.
- 5.2 Cylinder with one main exhaust port.
- 5.3 Maximum bore of cylinder = 54,035 mm (measured 10 mm above the exhaust port).
- 5.4 Cylinder must be marked with the "ROTAX" logo (see pictures below).

5.5.1 **125 Junior MAX**

Cylinder without pneumatic timed exhaust valve. Cylinder has to be marked either with identification code 223 999, 223 998 or 223 994.



5.5.2 **125 MAX**

Cylinder with pneumatic timed exhaust valve. Cylinder has to be marked either identification code 223 997, 223 996 or 223 993



5.6 Height of cylinder has to be 87 mm $-0,05/+0,1$ mm.



5.7.1 All transfer ports and passages have cast finish surface except some removal (done by the manufacturer) of cast burr at the inlet passage. All ports have chamfered edges to prevent ring snagging. Any additional machining is not permitted. The top edge of exhaust port may show some pre-existing machining from the manufacturer. The sealing flange for the exhaust socket may show signs of machining from the manufacturer.



5.7.2 All ports have chamfered edges.
Any additional machining is not permitted.

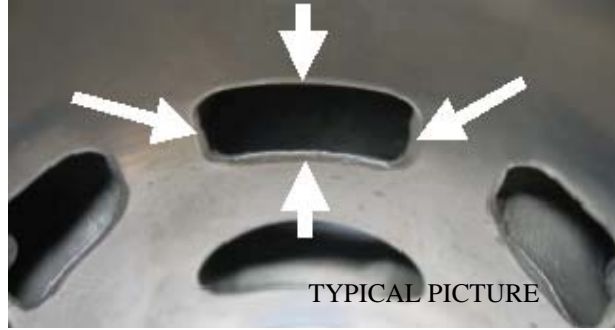

Cylinders marked 223 993 and 223 994 may show CNC machining done by the manufacturer at the upper edge of the central boost port.

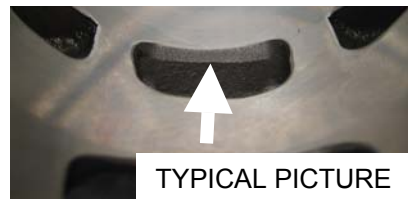

5.7.3 The sealing flange for the exhaust socket may show either cast finish surface or signs of machining from the manufacturer.



5.7.4 The top edge of the exhaust port may show either just a cast finish surface,



or signs of a CNC machining,

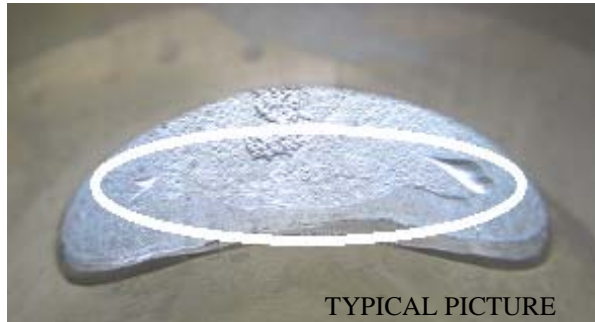

or signs of CNC machining in combination with signs of manual grinding.

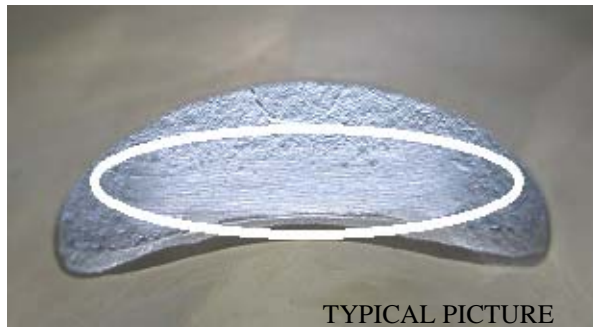

The exhaust port may show partial manual grinding done by the manufacturer to eliminate minor casting defects and to eliminate the NIKASIL burr at the end of the NIKASIL plating.

Cylinders 223 993 and 223 994, exhaust port may show machining done by the manufacturer all around.



5.8

Exhaust port timing

The "exhaust port timing" (distance from the top of the cylinder to the top of the exhaust port) has to be checked by means of the template (ROTAX part no. 277 397).

Insert the template into the cylinder, that the template is touching the cylinder wall and that the finger of the template is located in the middle of the exhaust port (highest point).

Move the template upwards, until the finger is touching the top edge of the exhaust port. Insert a feeler gauge between the top of the cylinder and the feeler gauge. It may not be possible to fit the feeler gauge specified below.

**125 Junior MAX: 0,90 mm for cylinder 223 999 / 223 998
1,10 mm for cylinder 223 994**

125 MAX: 0,75 mm

For cylinder 223 993 (125 Max), it is also legal if the template doesn't fit in at all.

NOTE: Take care to use the corresponding gauge (JUN or MAX) of the template for the respective cylinder!

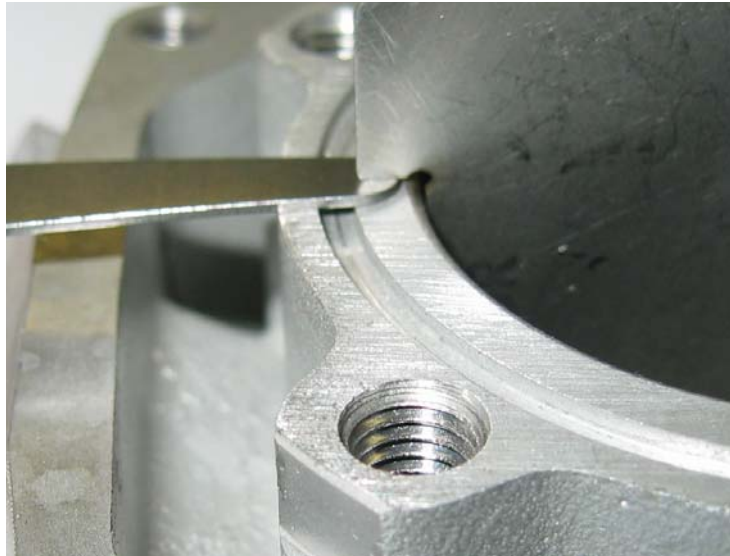



5.9

Exhaust valve (125 MAX only)

If the piston is moved in direction top of cylinder and first time covering completely the exhaust port, it must be possible to insert the exhaust valve gauge (ROTAX part no. 277 030) until it stops at the surface of the cylinder (a feeler gauge of 0,05 mm must not be possible to fit in).

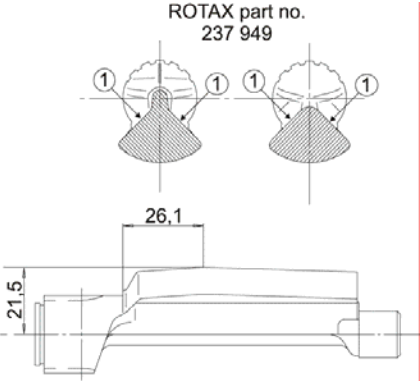

Inlet system	6.1 6.2 6.3 6.4	<p>Inlet manifold is marked with the name "ROTAX" and the identification code "267 915".</p>  <p>Some factory flash removal may be present at the conjunction of the inside contour and the carburettor stop mounting face. This is a manual trimming operation consisting of a small corner break of less than 3 mm in width. No additional grinding or machining is permitted. .</p> <p>The reed valve assembly is equipped with 2 petal stops and 2 reeds, each having 3 petals.</p> <p>The thickness of the reeds is 0,6 mm +/- 0,08 mm</p>
Crankshaft	7.1 7.2 7.3	<p>Stroke 54,5 mm +/-0,1 mm</p> <p>Con rod has to show forged numbers "213", "365" or "367" on shaft.</p>  <p>Shaft of con rod is not machined (copper plated). Grinding or polishing of shaft of con rod is not permitted.</p>
Balance shaft	8.1 8.2 8.3 8.4	<p>Balance shaft and balance gears must be installed.</p> <p>Only configurations of part no. 237 948 and 237 949 are legal.</p> <p>Surface (1) is not machined and must show cast surface.</p> <p>Measurement from centre of balance shaft to outer diameter of fly weight of balance shaft at defined length must not be lower than specified.</p>

	8.5	<p>The minimum weight of the dry balance shaft must not be lower than 255 grams for balance shaft ROTAX part no. 237 949 (equal with 237 948).</p> 
Crankcase	9.1	As supplied by the manufacturer. No grinding/polishing is permitted in the two main transfer passages as well as in the crank area.

**9.2 Technical Specification (outside the engine seal) for ROTAX kart engines
125 Junior MAX (15 kW)
125 MAX (21 kW).**

It is the responsibility of the competitor to check his equipment (all components outside the engine seal and mentioned below), to assure that his equipment is in line with the technical specification below!

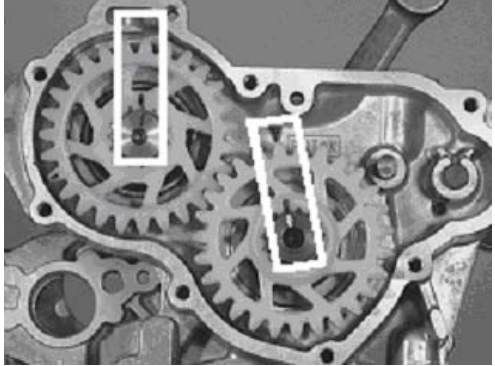
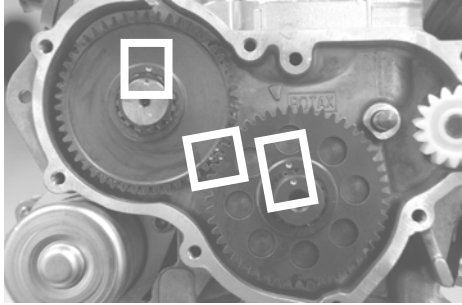
Balance drive	10.1	<p>Balance gears must be installed and must be aligned according to the instruction in the repair manual. Old “plastic” version of the balance gears must only be used with old type of centrifugal clutch. <u>Because the old clutch will not be legal after 2010, the plastic balance gears will not be legal in 2011.</u></p> <div data-bbox="581 520 751 569" style="border: 1px solid black; padding: 2px; display: inline-block;">Version 1</div> 
	10.2	<p>Balance gears must be installed and must be aligned according to the instruction in the repair manual. New version “steel” balance gears can be used with old as well as new type of centrifugal clutch.</p> <div data-bbox="581 1062 751 1110" style="border: 1px solid black; padding: 2px; display: inline-block;">Version 2</div>  <p>Mixing of steel balance gears of different width (6,0 and 9,0 mm) is strictly forbidden.</p>
	11.1 11.2 11.3 11.4	<p>DENSO digital battery ignition, variable ignition timing, no adjustment necessary and possible.</p> <p>Race officials may request at any time that the competitor replace the ignition coil with a new unit provided by the race administration.</p> <p>The casting of the ignition coil has to show the following in casting "129000-" and "DENSO".</p> <p>Ignition coil must show 3 pins at the terminal.</p> <p>Connector housing of ignition coil must have either black or green colour.</p>

Ignition system	11.5	<p>The ignition coil has to be fixed by means of 2 original silent blocks to the gearbox cover. Only in case of chassis component interference with the original mounting location of the ignition coil, a supplementary extension bracket, rigidly constructed and fabricated of solid metal, of minimum dimensions and attached to the original case mounting holes, is permitted for mounting of the coil.</p>
	11.6	<p>Minimum length of ignition wire (high tension wire) is 210 mm from outlet of cable at ignition coil to outlet of cable at spark plug connector (= the visible length of wire)</p> <p>Ignition coil must be in working condition (to be tested in case of doubt)</p>
	11.7	<p>The pick up must be marked with the numbers 029600-0710, followed by a variable production code in the 2nd line.</p> <p>HINT: In case of doubt an easy check is to place a steel ball (3-5 mm in diameter) on the pickup (engine side), the steel ball must stay in the centre of the pickup surface.</p>
	11.8	<p>Spark plug: DENSO Iridium IW 24 or 27 or 29 or 31 or 34 For Canada: NGK BR ... EIX is also legal</p>
	11.9	<p>Spark plug cap must be marked with "NGK TB05EMA".</p>
	11.10	<p>Original battery must be used: FIAMM-GS type FGHL 20722 or FGH 20902 or YUASA 6,5 or ROTAX RX7-12B.</p>
	11.11	<p>Battery must be fitted with the original battery clamp and battery cover (see illustration below) and must be fixed to the chassis with at least 2 screws. Position of the battery is free.</p>

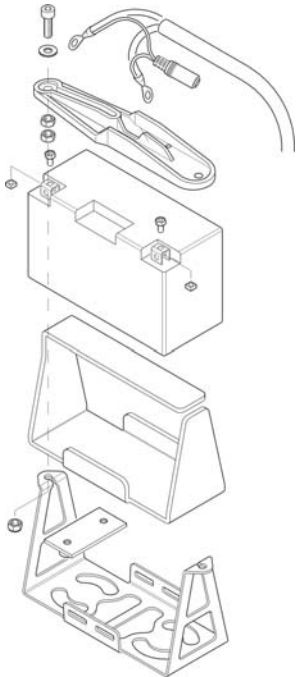
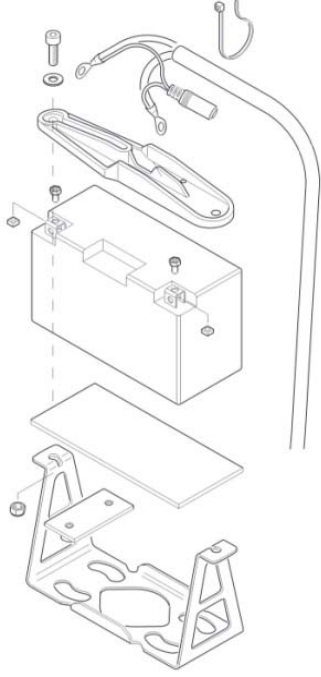
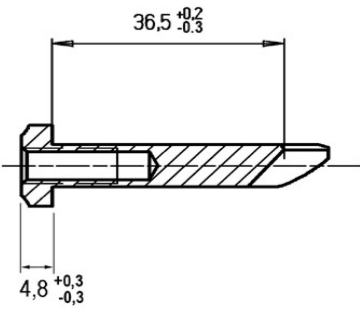

	11.12	<p>Battery must be mounted with all components as shown in the illustration either like version 1 or like version 2.</p> <p>Version 1</p>  <p>Version 2</p> 
Exhaust valve	<p>12.1</p> <p>12.2</p> <p>12.3</p>	<p>Configuration 125 MAX only!</p> <p>As supplied by the manufacturer with no modification allowed. Compression spring must be fitted.</p> <p>Length of the exhaust valve is 36,5 mm $+0,20$ mm $-0,30$ mm.</p> <p>Width of colar is 4,8 mm $+/-0,3$ mm</p> 

Centrifugal clutch

13.1.1 Dry centrifugal clutch, engagement r.p.m. maximum at 3.000 r.p.m.
 That means that the kart (without driver) must start to move latest at an engine speed of maximum 3.000 r.p.m. This is valid for old as well as new centrifugal clutch.

Old version clutch (Note: 2010 is the last year for this version)

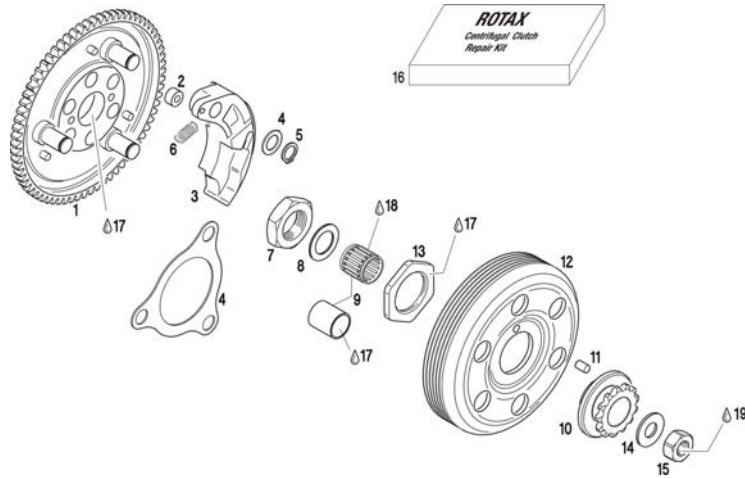

13.1.2 New steel clutch version

There are two versions of the clutch shoe (element part # 3 on the diagram) and both are legal to be used. The older version of the clutch shoe can be either untreated or nitrated configuration.

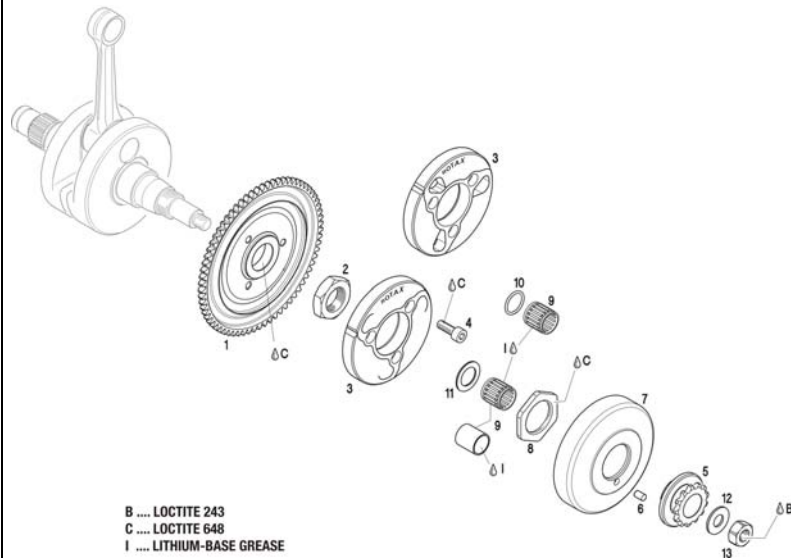

13.2 Engines using the new steel clutch model must be fitted the new needle cage bearing 15X19X17 (item 9) as well as the new O-Ring 12X2,5 (item 10) only.

Except if the plain bearing 15X17X20 (item 9) designed for the 11 teeth sprocket is used, in this case no O-ring must be used.

No extra lubrication or additional substance allowed inside the clutch drum additional to the grease that originates from lubrication of the needle cage bearing and enters the clutch area.

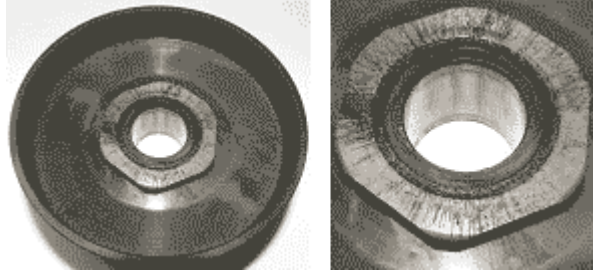

Picture shows worst case scenario in case grease exits the bearing area even O-Ring is installed.

Only fixation nut as well as inside of drum show signs of grease, running surface of clutch is completely dry.

In case Plain bearing for the 11 teeth sprocket is used, clutch area must be absolutely free grease or any additional substance.

13.3 Steel clutch (with old or new clutch shoe) and clutch drum must be within following specifications:

13.3.1 **Vertical width of the clutch shoe**

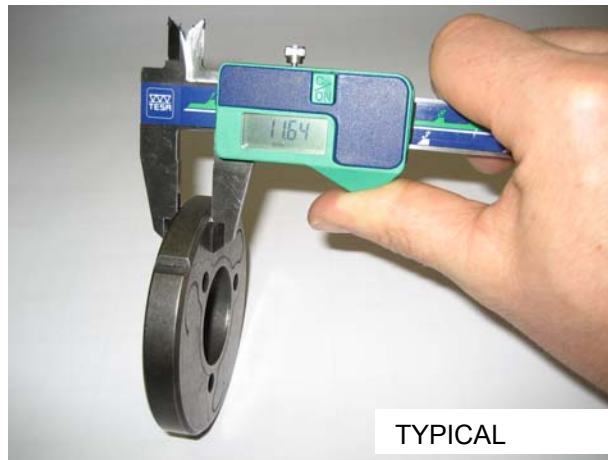

Minimum: 11,45 mm.

13.3.2 **Horizontal width of the clutch shoe**



Measurement has to be done at the 3 open ends of the clutch shoes, 5 - 10 mm from the machined groove (all clutch shoes must be completely closed at measurement - no gap visible).

No measurement may be below 24,10 mm.

13.3.3 **Outer diameter of clutch drum**

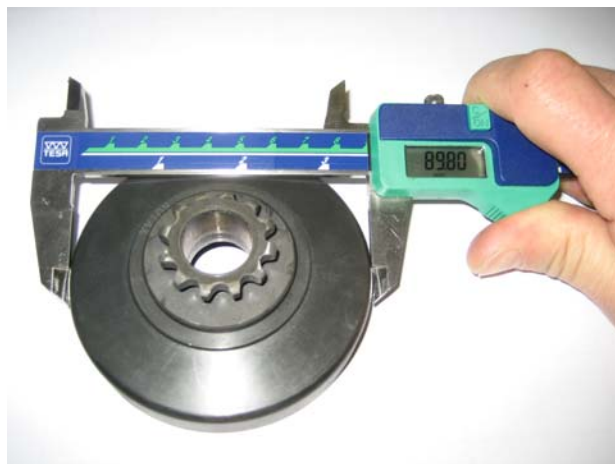

Diameter has to be measured with a sliding calliper just beside the radius from the shoulder (not at the open end of the clutch drum).

Minimum diameter: 89,50 mm.

13.3.4 **Inner diameter of clutch drum**

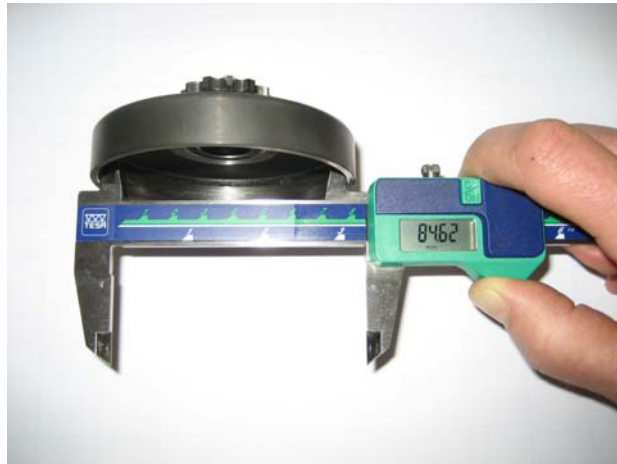

The inner diameter has to be measured with a sliding calliper. The measurement has to be done in the middle of the clutch drum (in the contact area of the clutch drum).



Maximum diameter: 84,90 mm.

13.3.5 **Height of sprocket with clutch drum assembly**

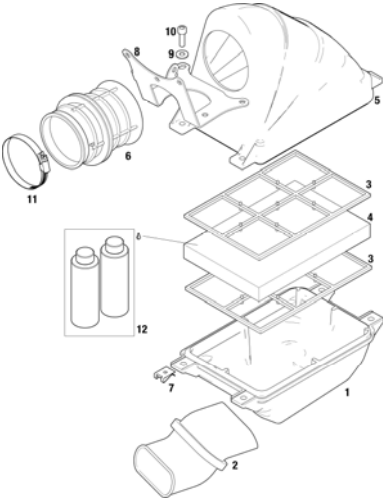

Minimum height: 33,90 mm

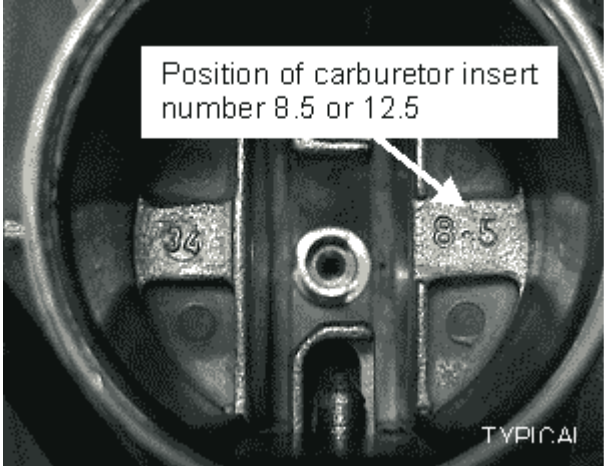
Intake silencer	14.1	<p>Intake silencer with integrated, washable air filter has to be used with all parts as shown at illustration and has to be mounted on the support bracket with two screws (in dry and wet race condition).</p> 
	14.2	Intake silencer case bottom is marked on the inside with the ROTAX part no. 225 015.
	14.3	Intake silencer case top is marked on the inside with the ROTAX part no. 225 025.
	14.4	Air filter must be installed as shown in illustrations above.
Carburettor	15.1	<p>DELL'ORTO carburettor</p> <p>15.2 "VHSB 34" cast in the housing of the carburettor.</p> <p>15.3 "QD" or "QS" stamped in the housing of the carburettor.</p> <p>15.4 The complete inlet bore in the casing of the carburettor must show cast surface</p> <p>15.5 Needle jet stamped with "FN 266"</p> <p>15.6 The carburettor slide must show with size "40" in casting and the bottom end of the slide must show cast surface.</p> <p>15.7 Jet needle stamped with "K27" or "K98"</p> <p>15.8 Following two combination of floats, idle jets and idle jet inserts are legal:</p> <p>15.8.1 <u>Combination 1:</u></p> <p>Floats are marked with "gr 5.2"</p> <p>Idle jet is stamped with the digits "30"</p> <p>Idle jet insert is stamped with the digits "30"</p> <p>Carburettor insert 12.5 (see illustration on next page)</p>

	15.8.2	<p><u>Combination 2:</u></p> <p>Floats are marked with “gr 3.6” Idle jet is stamped with the digits “60” Idle jet insert is stamped with the digits “60” Carburettor insert 8.5 (see illustration below)</p>  <p>15.9 Start jet is stamped with the digits “60”</p> <p>15.10 Settings of the carburettor adjustment screws are free.</p> <p>15.11 Except for Micro-Max, main jets smaller than size 160 or bigger than 200 are not recommended by ROTAX (except in high altitude conditions)</p> <p>15.12 Main jets smaller than size 160 and bigger than size 200 are legal also if they are not available from ROTAX.</p> <p>15.13 A minimum required size of main jet may be determined for each race event by a “Supplementary Regulation”.</p>
Fuel pump	16.1	MIKUNI diaphragm pump, must be mounted on the support bracket (on the bottom or sideways) of the intake silencer.
Fuel filter	17.1	<p>Only the original fuel filter (see picture below) is allowed to be fitted between the fuel tank and the fuel pump.</p>  <p>No additional parts except the fuel line as well as fuel pump and the original fuel filter are legal to be mounted between fuel tank and carburettor.</p>
Radiator	18.1 18.2 18.3 18.4	<p>18.1 Single aluminium radiator as shown in illustration below.</p> <p>18.2 Cooling area: Height = 290 mm, width = 133 mm</p> <p>18.3 Thickness of radiator = 32 mm</p> <p>18.4 Place of fixing the radiator is on right side of engine.</p>

- 18.5 Radiator must be mounted with all components as shown in the illustration either like version 1 or like version 2. At version 2, there is two legal options to mount the radiator to the retaining plate (see drawing for details). At version 2, there is two different radiators with two different positions of the retaining plates (either pointing forward or backwards).
- 18.6 No additional cooling device is allowed. Tape applied around the radiator is the only allowed airflow control. The ape may not be removed from the radiator during operation on the track. All other means of airflow control through the radiator are prohibited.
- 18.7 The removal of the thermostat from the cylinder head cover is an acceptable configuration.

Version 1

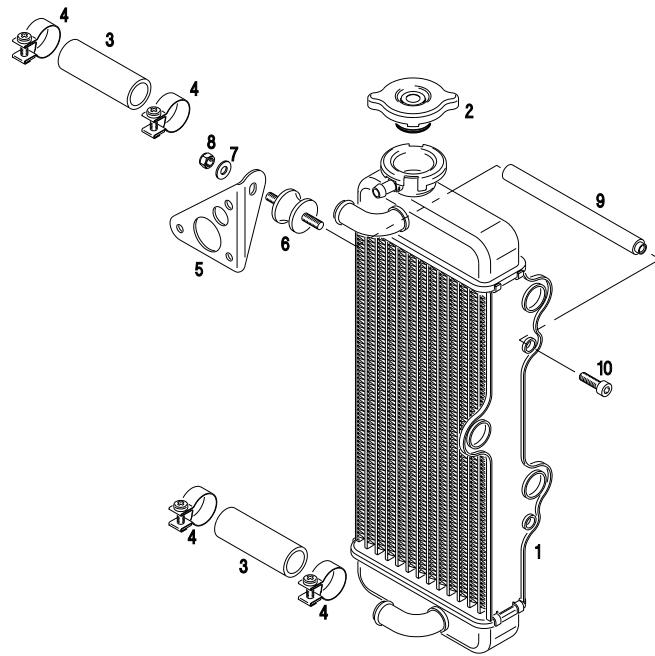
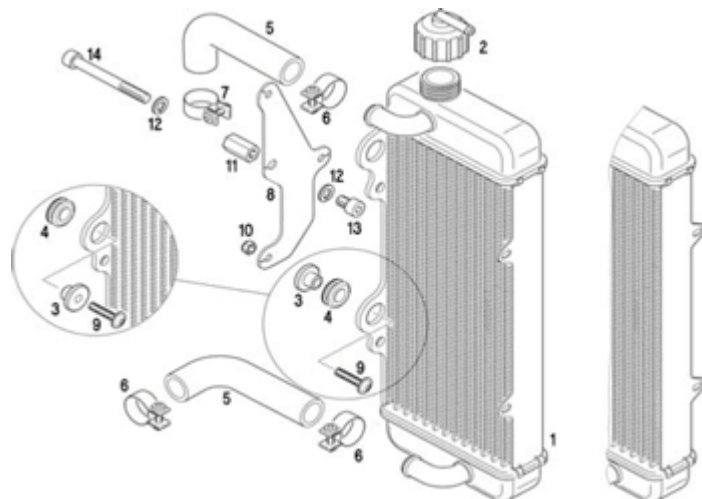

Illustration 5

Version 2





Radiator coolant

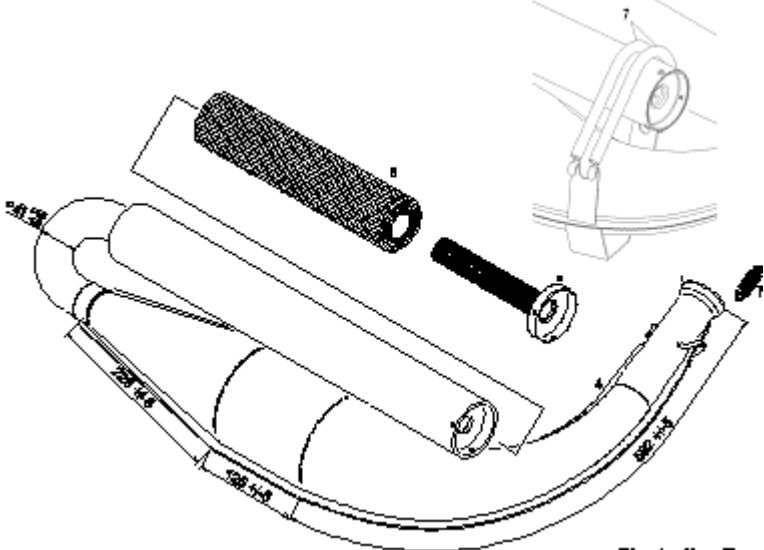

- 19.1 As glycol coolants are prohibited, plain water without any additives has to be used.

Exhaust system	<p>20.1</p> <p>20.2</p> <p>20.3</p> <p>20.4</p> <p>20.5</p> <p>20.6</p> <p>20.7</p> <p>20.8</p> <p>20.9</p> <p>20.10</p> <p>20.11</p> <p>20.12</p>	<p>Must be as supplied by BRP-POWERTRAIN and cannot be modified except for the replacement of the silencer absorption material and the use of threaded fasteners in place of the rivets for securing the silencer end cap.</p> <p>Standard exhaust socket must be used.</p> <p>Exhaust pipe with after muffler as shown in illustration. Both versions (version with welded on after muffler and version with after muffler fixed by two springs) are legal to be used.</p>  <p>Illustration 7</p> <p>Diameter of hole of end cap of (pos 6 on illustration above): Max 21,0 mm</p> <p>Length of inlet cone: 592 mm +/-5 mm (measured on outside from beginning of exhaust pipe until beginning of cylindrical part).</p> <p>Length of cylindrical part of exhaust pipe: 125 mm +/-5 mm.</p> <p>Length of end cone: 225 mm, +/-5 mm</p> <p>Outside diameter of 180° bent tube: 41mm +1,5 mm/-1,0 mm (measured at beginning and end of bend).</p> <p>Just one piece of original isolating mat is allowed to be used.</p> <p>The original exhaust system (tuned pipe and silencer) may not be modified, except for the addition of extra elements for further noise reduction.</p> <p>For measuring the exhaust gas temperature, it is allowed to weld on a socket on top of the exhaust, 50 mm from the ball joint.</p> <p>The use of maximum 4 pieces of original BRP-POWERTRAIN exhaust springs to fix the exhaust to the cylinder is allowed. (no safety wire allowed in exhaust flange area).</p>
Noise emissions	21.1	<p>Noise isolating mat (see illustration exhaust system) has to be replaced by an original BRP-POWERTRAIN spare part, if the noise emission is exceeding 92 dB (A).</p>

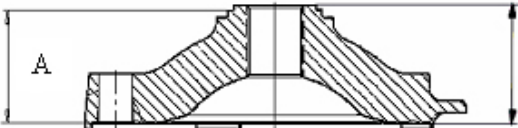
	21.2	<p>Noise emission measuring procedure:</p> <p>The measuring place has to be at section of the track where the engine is operated under full load and at a rpm range of 11.000 to 12.000 rpm.</p> <p>The microphone has to be installed 1 meter above the level of the track in a rectangular angle to the track.</p> <p>The distance between the microphone and the kart on the ideal line on the track has to be 7,5 meters.</p> <p>The kart has to be operated under full load at the ideal line on the track.</p>
--	------	--

9.3 Technical Specification (within the engine seal) for Rotax kart engine 125 MAX DD2 (24 kW)

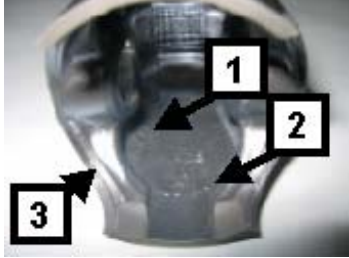
Squish gap	1.1	<p>125 MAX DD2 0,90 mm - 1,30 mm</p> <p>The squish gap must be measured with a certified slide gauge and by using a 2 mm tin wire. The crankshaft must be turned by hand slowly over TDC (top dead centre) to squeeze the tin wire. Recommended 2 mm tin wire : BRP-POWERTRAIN part no. 580 130</p> <p>The squish gap must be measured on the left and right side in the direction of the piston pin.</p> <p>The average value of the two measurements counts.</p>
Combustion chamber insert	<p>2.1</p> <p>2.1</p> <p>2.3</p> <p>2.4</p>	<p>Cast identification code has to be "223 389" or "223 389 1" or "223 389 2"</p> <p>Cast wording "ROTAX" and/or "MADE IN AUSTRIA" must be shown.</p>  <p>Heights of combustion chamber insert have to be 27,55 mm with a tolerance of +0,0/-0,1 mm (A) and 28,80 mm with a tolerance of +/- 0,2 mm (B).</p>  <p>The profile of the combustion chamber insert has to be checked with a template (ROTAX part no. 277 390). The crack of light between the template and the profile of the combustion chamber insert has to be the same over the whole profile.</p> <p>NOTE: This check is just for reference. In case of doubt detailed measurements have to be performed to define conformity or non-conformity.</p> 

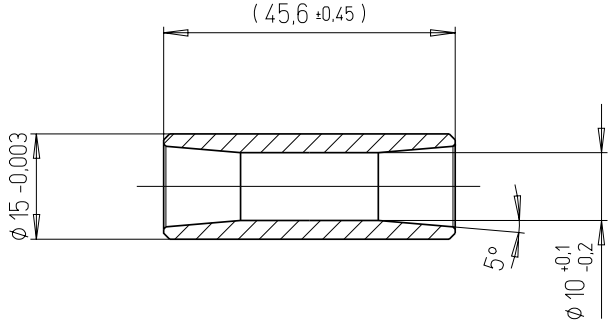
<p>Piston with ring assembly</p>	<p>3.1 3.2 3.3</p>	<p>Original, coated or uncoated, aluminium, cast piston with one piston ring. The piston has to show on the inside the cast wording "ELKO" (1) and "MADE IN AUSTRIA" (2).</p> <p>Machined areas are: Top end of piston, outside diameter, groove for the piston ring, bore for the piston pin, inside diameter at bottom end of piston and some pre-existing factory removal (3) of flashing at the cut out of the piston skirt. All other surfaces are not machined and have cast surface.</p>  <p>Original, 1 mm, magnetic, rectangular piston ring. Piston ring is marked either with "E CRY K" or "ROTAX 215 547".</p> 
<p>Gudgeon pin</p>	<p>4.1 4.2 4.3</p>	<p>Gudgeon pin is made out of magnetic steel.</p> <p>Dimensions must be according to the drawing</p> <p>The minimum weigh of the gudgeon pin must not be lower than 32,10 grams.</p> 
<p>Cylinder</p>	<p>5.1 5.2 5.3 5.4</p>	<p>Light-alloy-cylinder with GILNISIL-plating. Any re-plating of cylinder is not allowed.</p> <p>Cylinder with one main exhaust port and two sides exhaust ports.</p> <p>Maximum bore of cylinder = 54,035 mm (measured 10 mm above the exhaust port).</p> <p>Cylinder has to be marked with the "ROTAX" logo (see picture below).</p>

- 5.5 Cylinder with pneumatic timed exhaust valve. Cylinder has to be marked with the identification code 613 930, 613 931 or 613 933.



- 5.6 Height of cylinder has to be 86,7 mm $-0,05/+0,1$ mm.



- 5.7.1 All transfer ports and passages have cast finish surface except some removal (done by the manufacturer) of cast burr at the inlet passage.



- 5.7.2 All ports have chamfered edges.
Any additional machining is not permitted.

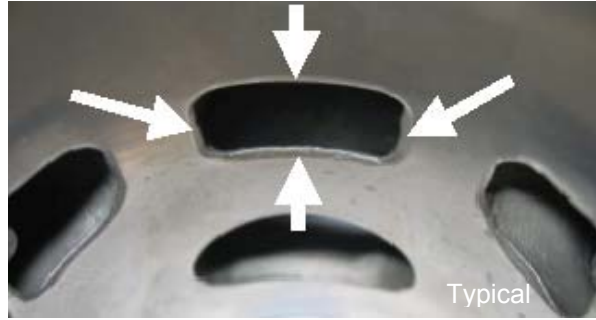

Cylinders marked 613 933 may show factory machining done by the manufacturer at the upper edge of the central boost port.

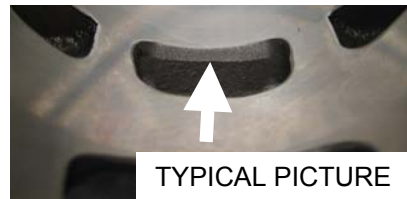

- 5.7.3 The sealing flange for the exhaust socket may show either cast finish surface or signs of machining from the manufacturer.



- 5.7.4 The top edge of the exhaust port may show either just a cast finish surface...

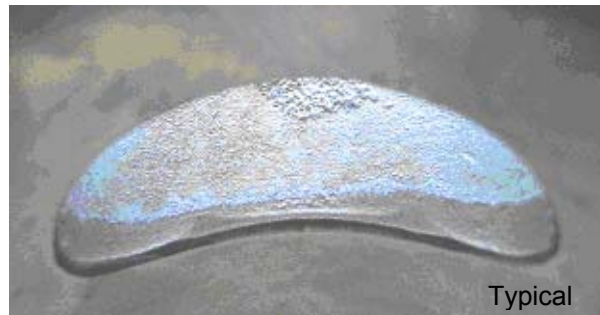

or signs of a CNC machining ...

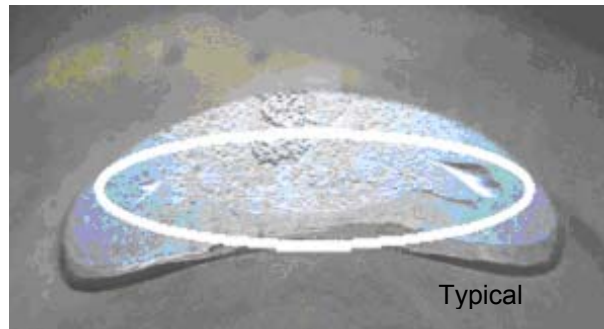

or signs of CNC machining in combination with signs of manual grinding.

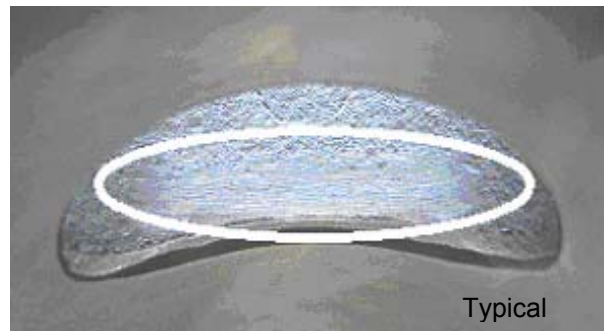

The exhaust port may show partial manual grinding done by the manufacturer to eliminate minor casting defects and to eliminate the NIKASIL burr at the end of the NIKASIL plating.

Cylinder 613 933 exhaust port may show factory machining all around.



5.8 Exhaust port timing

The "exhaust port timing" (distance from the top of the cylinder to the top of the exhaust port) has to be checked by means of the template (ROTAX part no. 277 397).

Insert the template into the cylinder, that the template is touching the cylinder wall and that the finger of the template is located in the middle of the exhaust port (highest point). Move the template upwards, until the finger is touching the top edge of the exhaust port. Insert a feeler gauge between the top of the cylinder and the feeler gauge. It may not be possible to fit the feeler gauge specified below.

125 MAX DD2: 0,75 mm

Cylinders marked 613 933 are legal even if the template doesn't fit in at all.

NOTE: Take care to use the corresponding gauge of the template (DD2) for the respective cylinder!



5.9 If the piston is moved in direction top of cylinder and first time covering completely the exhaust port, it must be possible to insert the exhaust valve gauge (ROTAX part no. 277 030) until it stops at the surface of the cylinder (a feeler gauge of 0,05 mm must not be possible to fit in).



Inlet system

6.1 Inlet manifold is marked with the name "ROTAX" and the identification code "267 410".



	6.2	Some factory flash removal may be present at the conjunction of the inside contour and the carburettor stop mounting face. This is a manual trimming operation consisting of a small corner break of less than 3 mm in width. No additional grinding or machining is permitted.
	6.3	The reed valve assembly is equipped with 2 petal stops and 2 reeds, each having 3 petals.
	6.4	The thickness of the reeds is 0,6 mm +/- 0,08 mm.
Crankshaft	7.1	Stroke 54,5 mm +/-0,1 mm
	7.2	Con rod has to show forged numbers "213", "365" or "367" on shaft. 
	7.3	Shaft of con rod is not machined (copper plated). Grinding or polishing of shaft of con rod is not permitted.
2-speed gearbox	8.1	Primary shaft with 19 teeth for 1st gear and 24 teeth for 2nd gear.
	8.2	Idle gear for 1st gear has to have 81 teeth.
	8.3	Idle gear for 2nd gear has to have 77 teeth.
Crankcase	9.1	As supplied by the manufacturer. No grinding/polishing is permitted in the two main transfer passages as well as in the crank area.

9.4 Technical Specification (outside the engine seal) for ROTAX kart engine 125 MAX DD2 (24 kW)

It is the responsibility of the competitor to check his equipment (all components outside the engine seal and mentioned below), to assure that his equipment is in line with the technical specification below!

Ignition system	10.1	DENSO digital battery ignition, variable ignition timing, no adjustment necessary and possible. Race officials may request at any time that the competitor replace the ignition coil with a new unit provided by the race administration.
	10.2	The casting of the ignition coil has to show the following in casting "129000-" and "DENSO".
	10.3	Ignition coil must show 4 or 6 pins at the terminal.
	10.4	Connector housing of ignition coil must have either white or grey colour.
	10.5	The ignition coil has to be fixed by means of 2 original silent blocks to the crankcase. Only in case of chassis component interference with the original mounting location of the ignition coil, a supplementary extension bracket, rigidly constructed and fabricated of solid metal, of minimum dimensions and attached to the original case mounting holes, is permitted for mounting of the coil.

	10.6	<p>Minimum length of ignition wire (high tension wire) is 210 mm from outlet of cable at ignition coil to outlet of cable at spark plug connector (= the visible length of wire)</p> <p>Ignition coil must be in working condition (to be tested in case of doubt)</p>
	10.7	<p>The pick up must be marked with the numbers 029600-0710, followed by a variable production code in the 2nd line.</p> <div data-bbox="842 394 1154 663" data-label="Image"> </div> <p>HINT: In case of doubt an easy check is to place a steel ball (3-5 mm in diameter) on the pickup (engine side), the steel ball must stay in the centre of the pickup surface.</p>
	10.8	<p>Spark plug: DENSO Iridium IW 24 or 27 or 29 or 31 or 34 For Canada: NGK BR ... EIX is also legal</p>
	10.9	<p>Spark plug cap must be marked with "NGK TB05EMA".</p>
	10.10	<p>Original battery must be used: FIAMM-GS type FGHL 20722 or FGH 20902 or YUASA 6,5 or ROTAX RX7-12B</p>
	10.11	<p>Battery must be fitted with the original battery clamp and battery cover (see illustration below) and must be fixed to the chassis with at least 2 screws.</p> <p>Position of the battery is free.</p> <p>RM1 kart has to have fitted the battery on the left side in front of the radiator. Original battery clamp and battery cover must be used.</p>

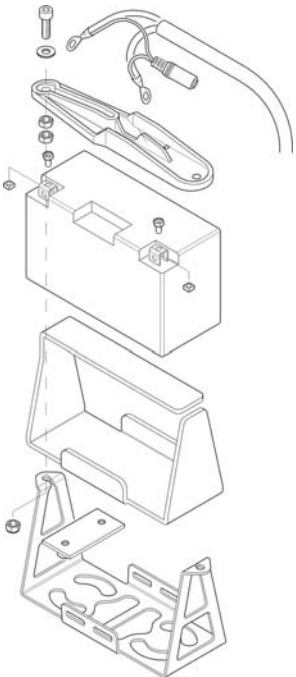
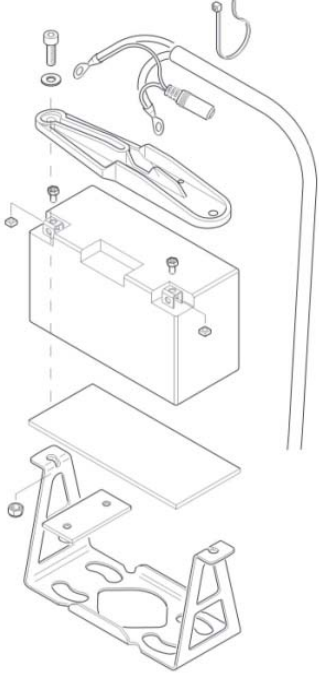
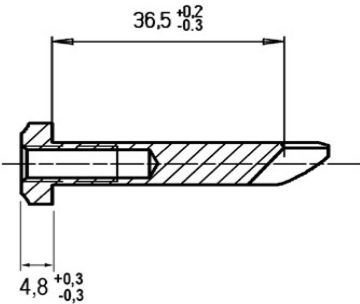
	10.12	<p>Battery must be mounted with all components as shown in the illustration either like version 1 or like version 2.</p> <p>Version 1</p>  <p>Version 2</p> 
Exhaust valve	<p>11.1</p> <p>11.2</p> <p>11.3</p>	<p>As supplied by the manufacturer with no modification allowed. Compression spring must be fitted.</p> <p>Length of the exhaust valve is 36,5 mm +0,20 mm /-0,30 mm.</p> <p>Width of collar is 4,8 mm +/-0,3 mm</p> 
Balance drive	<p>12.1</p> <p>12.2</p>	<p>Balance drive gear must be fitted on crankshaft.</p> <p>Balance gear must be fitted on primary shaft and must be aligned with the balance drive gear according to the instruction in the repair manual.</p>

12.3 On the old version, flyweight of balance gear must show cast surface.

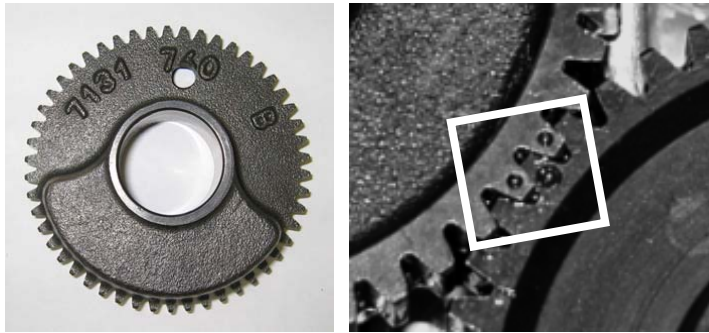

12.4 On the new version, flyweight of balance gear can show machined surface done by the manufacturer.

Dimension A (widest part of the balance weight) must be either 53 mm +/- 0,5 mm or 57 mm +/- 0,5 mm.

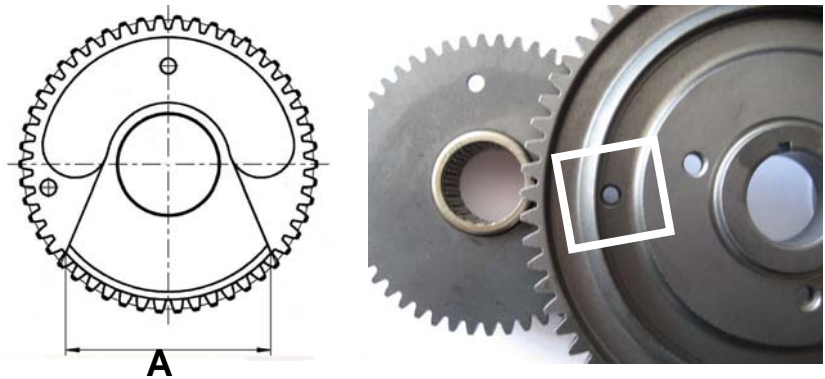

On the new version, the minimum weight of a dry balance gear including bearing must not be lower than 240 grams.

Centrifugal clutch

13.1 Centrifugal clutch in oil bath, engagement r.p.m. maximum at 4.000 r.p.m.

That means, that the kart (without driver) must start to move latest at an engine speed of maximum 4.000 r.p.m. This is valid for old as well as the new version of the centrifugal clutch.

Old version clutch (Note: 2010 is the last year for this version).

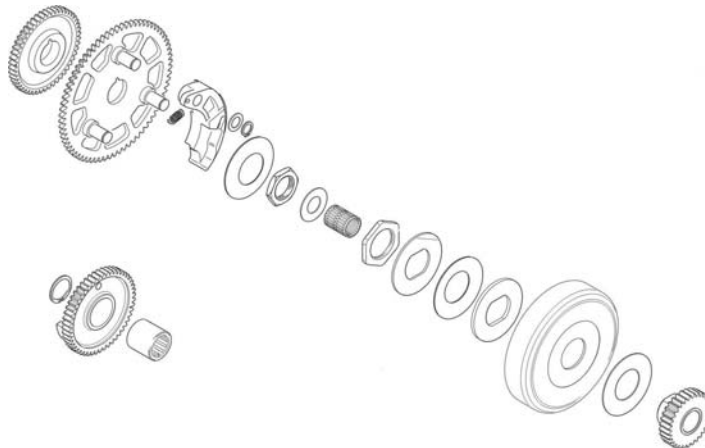

13.2 Clutch new version

There are two versions of the element part # 6 on the diagram (clutch shoe) and both are legal to be used. The older version of the clutch shoe can be either untreated or nitrated configuration.

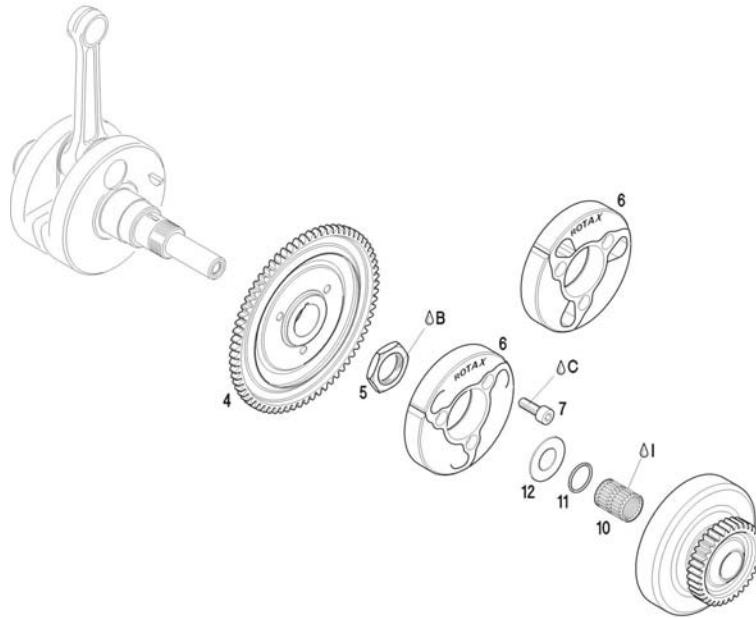

13.3 Steel clutch (old and new clutch shoe) and clutch drum for both versions must be within following specifications:

13.3.1 **Height of clutch**



Minimum: 14,45 mm

13.3.2 **Thickness of clutch shoe**



Measurement has to be done at the three open ends of the clutch shoes, 5-10 mm from the machined groove (all clutch shoes must be completely closed at measurement, no gap visible).

No measurement may be below 24,10 mm

13.3.3 **Outer diameter of clutch drum**

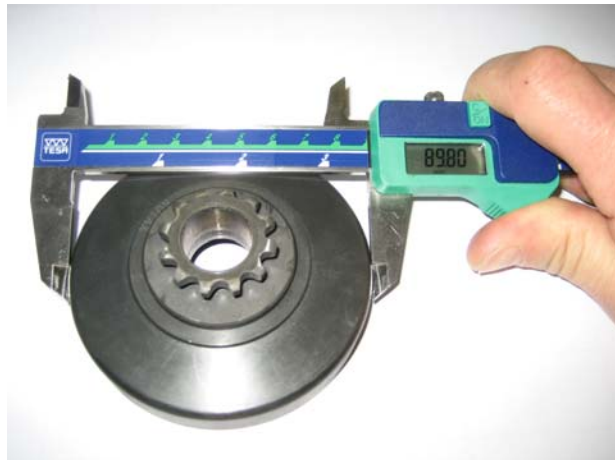

Diameter has to be measured with a sliding calliper just beside the radius from the shoulder (not at the open end of the clutch drum).

Minimum diameter: 89,50 mm.

13.3.4 **Inner diameter of clutch drum**



The inner diameter has to be measured with a sliding calliper. The measurement has to be done in the middle of the clutch drum (in the contact area of the clutch drum).

Maximum diameter: 84,90 mm.

13.3.5 **Height of sprocket with clutch drum assy.**

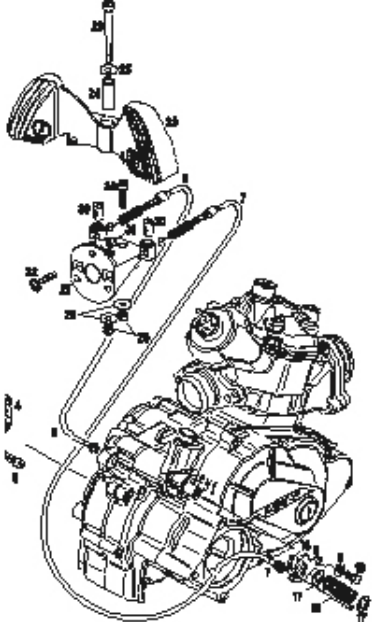

Minimum height: 33,90 mm

Primary drive	14.1	<p>Original primary drive gears of following gear ratio options must be used.</p> <table border="0"> <thead> <tr> <th>Drive gear</th> <th>Driven gear</th> </tr> </thead> <tbody> <tr> <td>32</td> <td>65</td> </tr> <tr> <td>33</td> <td>64</td> </tr> <tr> <td>34</td> <td>63</td> </tr> <tr> <td>35</td> <td>62</td> </tr> <tr> <td>36</td> <td>61</td> </tr> <tr> <td>37</td> <td>60</td> </tr> <tr> <td>38</td> <td>59</td> </tr> </tbody> </table> 	Drive gear	Driven gear	32	65	33	64	34	63	35	62	36	61	37	60	38	59
Drive gear	Driven gear																	
32	65																	
33	64																	
34	63																	
35	62																	
36	61																	
37	60																	
38	59																	
Gear shifting	15.1 15.2 15.3	<p>The 2-speed gearbox has to be operated with one of the two original supplied shift paddle configurations (plastic version and aluminium version), on the steering wheel via the two Bowden cables.</p> <p>For the plastic paddle version, cutting of the original shift paddle or adding of pads to the shift paddle is allowed to adjust the paddle to specific steering wheels.</p> <p>For the aluminium paddle version, cutting or addition of non original parts or material is forbidden.</p> <p>For plastic paddle version, original hub for steering wheel must be used.</p> <p>Version 1 (plastic paddle)</p> 																

Version 2 (aluminium paddle)

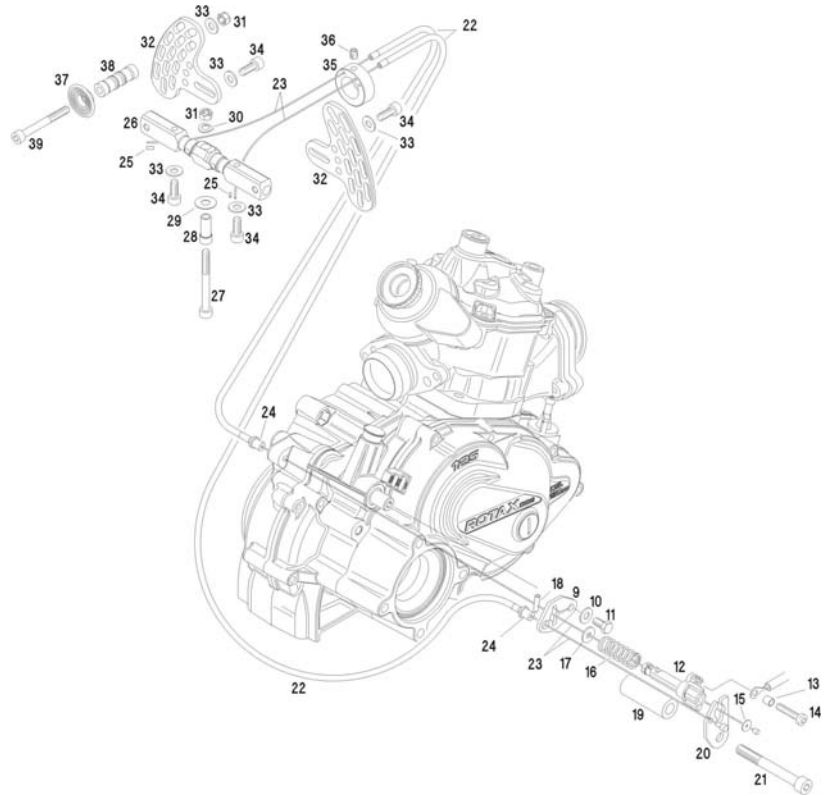

Intake silencer

- 16.1 Intake silencer with integrated, washable air filter as shown in illustration below.
- 16.2 The intake silencer case is marked on the inside with the ROTAX part no. 225 012.
- 16.3 The intake silencer cover is marked on the inside with the ROTAX part no. 225 022.
- 16.4 The air filter is marked with the ROTAX part no. 225 052.
- 16.5 The air filter must be assembled between the intake silencer case and the intake silencer cover that the whole area of the intake silencer case is covered.

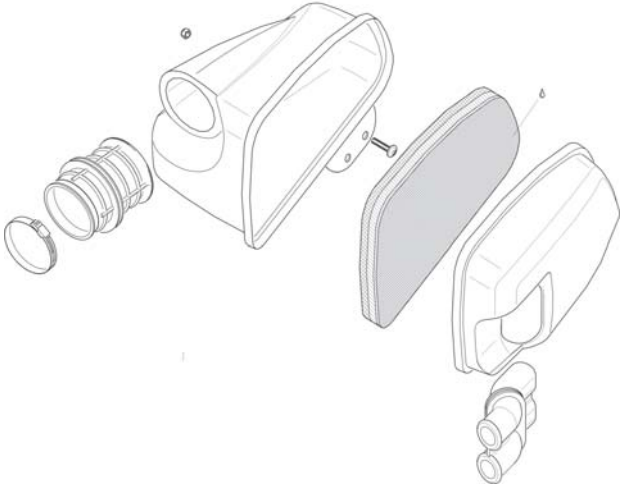
	16.6	<p>In case of a wet race it is allowed to seal the top of the air box using adhesive tape. For Canada, it is allowed to put tape on the top of the air box to avoid the opening of the air box even on dry condition.</p> 
Carburettor	17.1 17.2 17.3 17.4 17.5 17.6 17.7 17.8 17.8.1 17.8.2	<p>DELL'ORTO carburettor</p> <p>"VHSB 34" cast in the housing of the carburettor.</p> <p>"QD" or "QS" stamped in the housing of the carburettor.</p> <p>The complete inlet bore in the casing of the carburettor must show cast surface.</p> <p>Needle jet stamped with "FN 266"</p> <p>The carburettor slide must show with size "40" in casting and the bottom end of the slide must show cast surface.</p> <p>Jet needle stamped with "K27" or "K98"</p> <p>Following two combination of floats and idle jets are legal:</p> <p><u>Combination 1:</u> Floats are marked with "gr 5.2" Idle jet is stamped with the digits "30" Idle jet insert is stamped with the digits "30" Carburettor insert 12.5 (see illustration next page)</p> <p><u>Combination 2:</u> Floats are marked with "gr 3.6" Idle jet is stamped with the digits "60" Idle jet insert is stamped with the digits "60" Carburettor insert 8.5 (see illustration next page)</p>

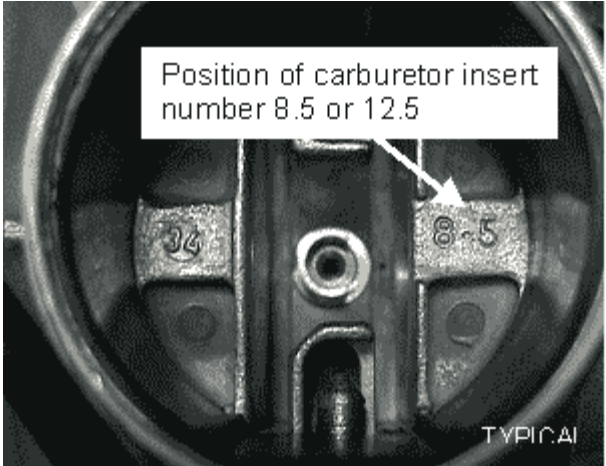
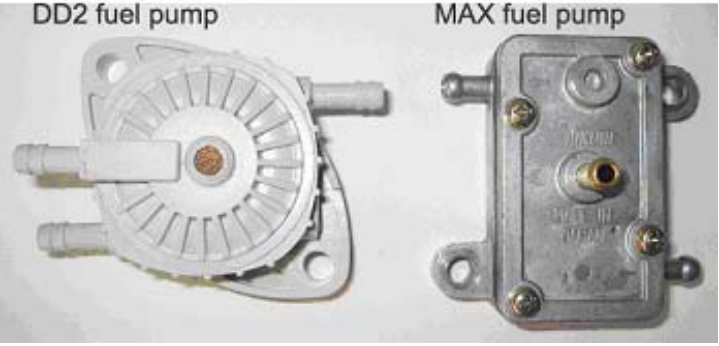
		 <p>Position of carburetor insert number 8.5 or 12.5</p> <p>34</p> <p>8-5</p> <p>TYPICAL</p> <p>17.9 Start jet is stamped with the digits “60”</p> <p>17.10 Settings of the carburettor adjustment screws are free.</p> <p>17.11 Main jets smaller than size 160 or bigger than 200 are not recommended by ROTAX (except in high altitude conditions)</p> <p>17.12 Main jets smaller than size 160 and bigger than size 200 are legal also if they are not available from ROTAX.</p> <p>17.13 A minimum required size of main jet may be determined for each race event by a “Supplementary Regulation”.</p>
Fuel pump	18.1	<p>Original diaphragm fuel pump (grey or black colour) must be fitted by means of two original silent blocks to the chassis or the engine.</p> <p>Optionally the MIKUNI diaphragm pump (as used on the 125 MAX engine) can be used.</p>  <p>DD2 fuel pump</p> <p>MAX fuel pump</p> <p>18.2 Centre line of fuel pump may not be higher than the centre line of the carburettor.</p>

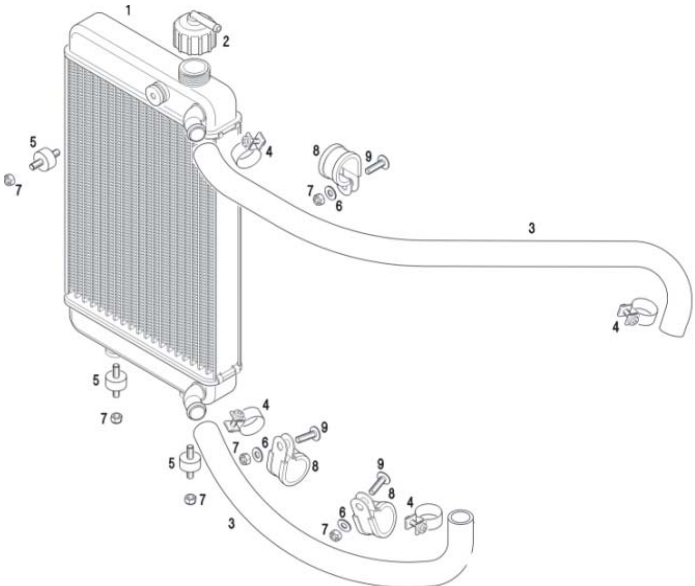
Fuel filter	19.1	<p>Only the original fuel filter (see attached picture) is allowed to be fitted between the fuel tank and the fuel pump.</p>  <p>No additional parts except the fuel line as well as the fuel pump and the original fuel filter are legal to be mounted between the fuel tank and the carburettor.</p>
Radiator	<p>20.1</p> <p>20.2</p> <p>20.3</p> <p>20.4</p> <p>20.5</p> <p>20.6</p> <p>20.7</p> <p>20.8</p>	<p>Single aluminium radiator (see illustration below).</p> <p>Name "ROTAX" is stamped in the top of the radiator.</p> <p>Cooling area: Height = 284 mm, width = 202 mm</p> <p>Thickness of radiator = 32 mm</p> <p>The radiator must be mounted on the left side of the kart beside the seat.</p> <p>The highest point of the radiator with cap may not be higher than 400 mm above the main tube of the kart chassis.</p> <p>No additional cooling device is allowed. Tape applied around the radiator is the only allowed air flow control. Tape may not be removed from the radiator during operation on the track. All other means of airflow control through the radiator are prohibited.</p> <p>The removal of the thermostat from the cylinder head cover is an acceptable configuration.</p> 
Radiator coolant	21.1	<p>As glycol coolants are prohibited, plain water without any additives has to be used.</p>

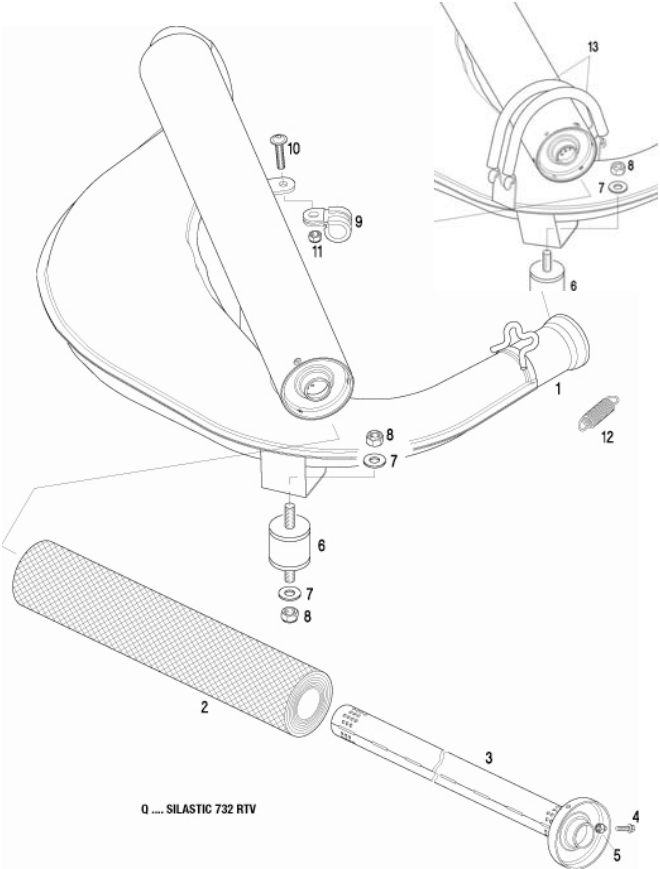
Exhaust system	<p>22.1</p> <p>22.2</p> <p>22.3</p>	<p>Must be as supplied by BRP-POWERTRAIN and cannot be modified except for the replacement of the silencer absorption material and the use of threaded fasteners in place of the rivets for securing the silencer end cap.</p> <p>Standard exhaust socket must be used.</p> <p>Exhaust pipe with after muffler (see illustration below). There are two version of the exhaust system, older version with welded on after muffler and new version with after muffler fixed by 2 springs. Both are legal to be used.</p>  <p>22.4</p> <p>22.5</p> <p>22.6</p> <p>22.7</p> <p>22.8</p>
Noise emissions	23.1	<p>Noise isolating mat (see illustration exhaust system) has to be replaced by an original BRP-POWERTRAIN spare part, if the noise emission is exceeding 94 dB (A).</p>

	23.2	<p>Noise emission measuring procedure:</p> <p>The measuring place has to be at section of the track where the engine is operated under full load and at a rpm range of 11.000 to 12.000 rpm.</p> <p>The microphone has to be installed 1 meter above the level of the track in a rectangular angle to the track.</p> <p>The distance between the microphone and the kart on the ideal line on the track has to be 7,5 meters.</p> <p>The kart has to be operated under full load at the ideal line on the track.</p>
--	------	--